

REV.	DRAWING NUMBER
A	PB0041421

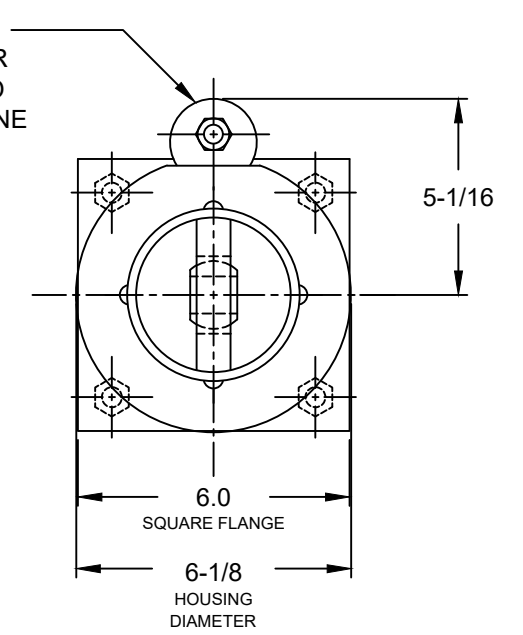

LOAD CAPACITY: 16,000 Lbs

ALL DIMENSIONS ARE FOR REFERENCE PURPOSES ONLY

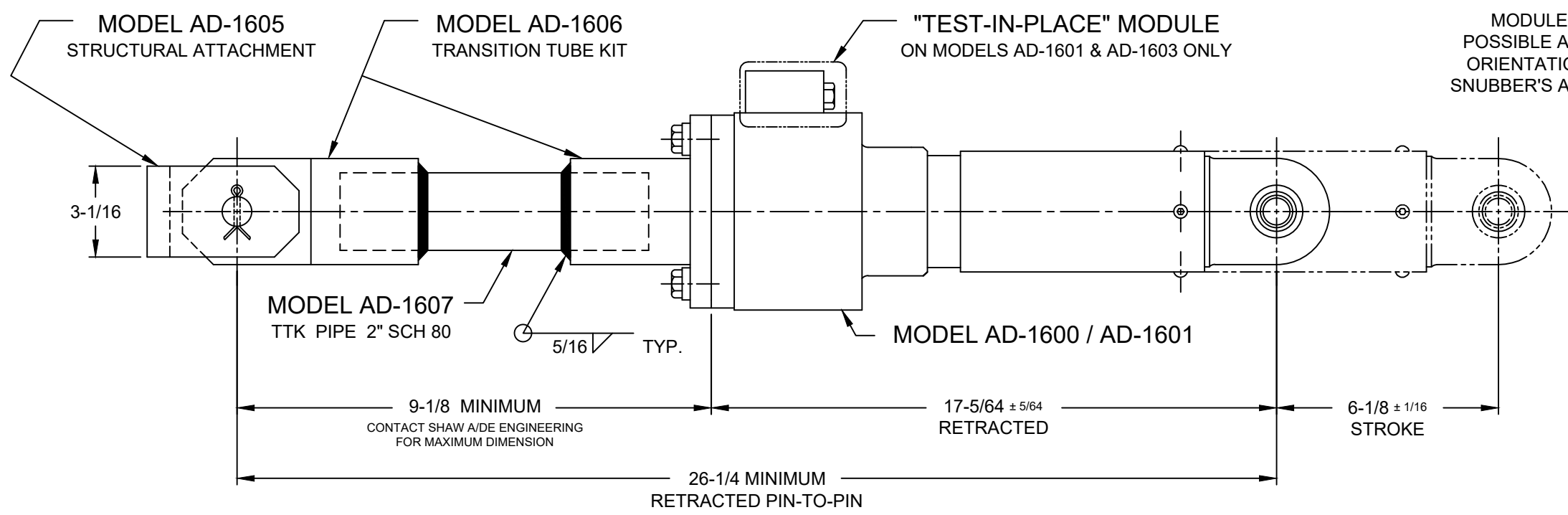
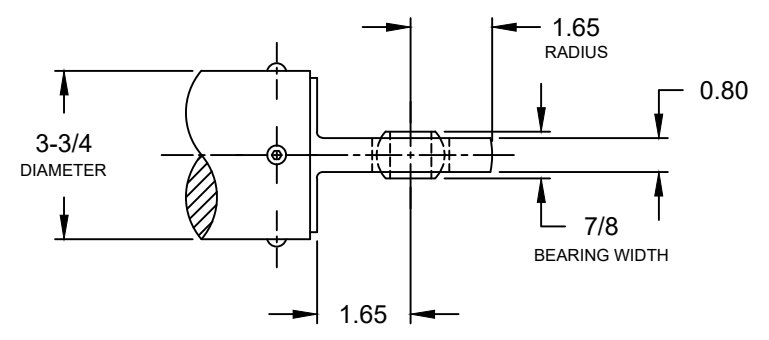
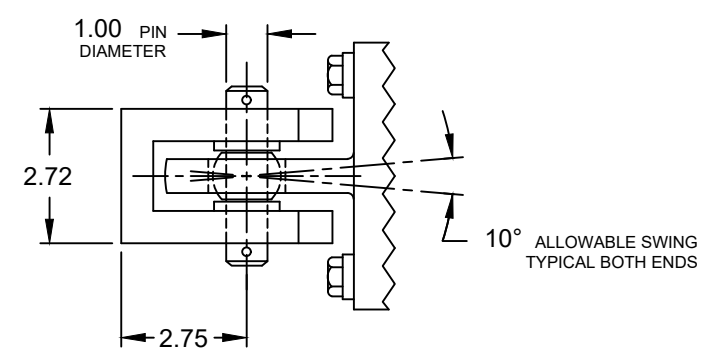
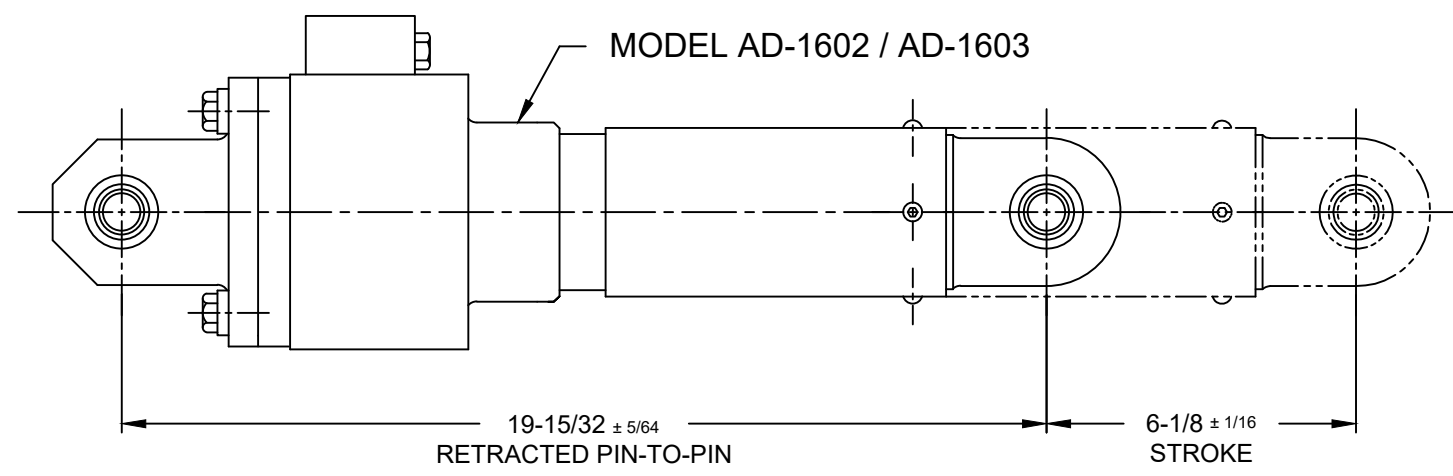
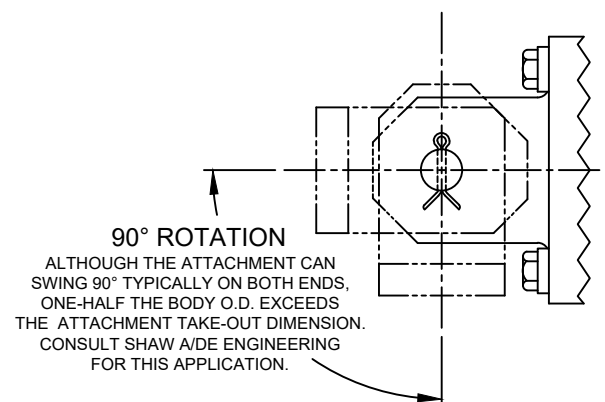

A	EDITORIAL CHANGES W/ DIMENSIONAL ADDITIONS & DELETIONS. ECM 2780
REV.	DESCRIPTION OF CHANGE

## FRONEK A/DE INC.

DESIGN ENVELOPE DIMENSIONS FOR MODEL AD-1600 SERIES MECHANICAL SNUBBER INCLUDING MODEL AD-1606 TRANSITION TUBE KIT AND MODEL AD-1605 STRUCTURAL ATTACHMENT

DRAWN / DATE: T. Morales 12-23-94	RELEASE ECM NO.: 2582
CHECKED / DATE: DAB 12-27-94	APPROVED / DATE: WP 12-27-94

DRAWING IS NOT TO SCALE UNLESS OTHERWISE NOTED UNLESS OTHERWISE SPECIFIED TOLERANCES SHALL BE  
 FRACTIONAL DIMS. ± 1/64 Inch  
 TWO DECIMALS ± .010 Inch  
 THREE DECIMALS ± .005 Inch  
 REMOVE ALL BURRS AND BREAK SHARP EDGES 1/64 MAX. STANDARD FINISH IS 125 RMS UNLESS NOTED OTHERWISE